

# Your Guide to the SunBox® SunSquare+™

You have just made the important decision to purchase your own SunSquare+™ light box. With this purchase, you join thousands of other individuals and hundreds of facilities worldwide who have chosen to use SunBox® products. Thank you for choosing The SunBox Company as your bright light source. We truly value your business.

SunBoxes are the most advanced and the highest quality bright light boxes on the market and are backed by a lifetime warranty—the longest in the industry. Founded in 1985, The SunBox® Company is the original manufacturer of high-intensity light boxes. We constantly strive for excellence and are proud of our products and service.

The SunSquare+™ is our largest, most powerful unit and provides up to 10,000 lux at a distance of 27". The large lighted surface area (451 square inches) offers a somewhat broader range of motion for the user than do smaller units. The large area of light output, along with the height-adjustable floor stand (included), makes the SunSquare+™ very well-suited for use in conjunction with exercise equipment.

Unlike other units on the market, your SunSquare+™ will remain cool to the touch. In addition, your SunSquare+™ contains full spectrum bulbs (with the UV filtered out). Many people find the "daylight replication" of full spectrum fluorescent tubes preferable to other types of artificial light, contributing less to headaches and eyestrain.

## IMPORTANT NOTES:

- In the event your unit is damaged or broken upon delivery, immediately report the problem to us by calling 800-548-3968 (toll-free) or 240-651-3286 so that the problem can be resolved in a timely fashion. This should be done within 5 days after you receive the unit.
- Occasionally, fluorescent lamps may break or become loose in shipping. If, upon receipt, the fixture does not light, see the instructions for replacing the bulb to open the unit and confirm if the bulb is intact. If your bulb is broken please contact us so we can send you a replacement.
- Please save all packing materials for reuse, should you need to return your unit to us. The SunBox® Company cannot be responsible for damage due to insufficient packing.
- To prevent electric shock, do not use this light in any extension cord or other outlet unless all three prongs of the plug can be inserted fully. Never remove the third (grounding) prong of this unit's plug. If you need to convert our 3-prong plug for a 2-prong outlet, make sure you properly ground the adapter to the wall plate. Otherwise, the light fixture might flicker while either on or off.

## General Guidelines for Use

Most people use their SunBox® light boxes as sources of bright light during the fall and winter months. Some people use them on overcast days at any time of year, or when their schedules or surroundings do not allow much exposure to natural sunlight. People working night shifts also use SunBoxes. Most people use light in the morning. If you use light too late in the day, it may disturb sleep.

To use a SunBox as a bright light source, the light should be in front of you, angled so that the light shines onto your face, and your eyes should be open. It is not necessary to look directly into the light; most people read, eat, work on computers or watch TV while using their SunBox. Eyeglasses or contact lenses may be worn, but heavily tinted glasses will reduce the amount of light received.

### ON HIGH SETTING (2 switches on), you receive:

10,000 lux at a distance of:	27"
5,000 lux	39"
2,500 lux	57"

### ON LOW SETTING (1 switch on), you receive:

10,000 lux at a distance of:	17"
5,000 lux	26"
2,500 lux	39"

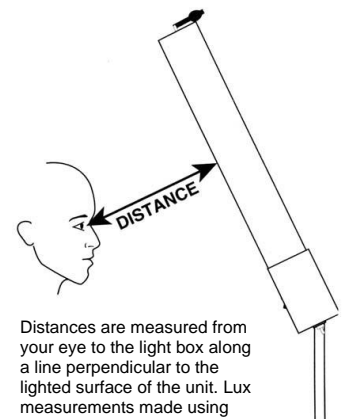

Distances are measured from your eye to the light box along a line perpendicular to the lighted surface of the unit. Lux measurements made using Extech LuxMeter model 407026.

Average use at the 10,000 lux distance is roughly 15-30 minutes per day. At 5,000 lux, that would be the equivalent of 40 minutes to 1 hour. At 2,500 lux, the light might be used for two to three hours. Actual time for a particular individual will vary. It usually takes some experimentation to find a routine that is right for you.

**The SunBox® Company • Frederick, MD 21701**  
**Phone 240-651-3286 • Fax: 301-977-2281**  
**Email: [orders@sunbox.com](mailto:orders@sunbox.com) • Website: [www.sunbox.com](http://www.sunbox.com)**

# SunSquare+™ Floor Stand Assembly

1. Using two Nuts, two Washers, and two Bolts, attach the Bracket Piece to the angled plate at the end of the Height Adjustment Bar. Be sure to attach these pieces tightly (use tools; don't just go by hand-tightness).

2. Attach the Vertical Bar to the top of the Base's crossbar. Use the remaining two Nuts, two Washers, and two Bolts. Be sure these are tight (use tools; don't just go by hand-tightness). Also be sure that the nut that is welded to the Vertical Bar is facing the back of the Stand. (The Base's crossbar is closer to the back than to the front.)

3. Stand the bottom half of the Stand upright (all 4 Casters on the floor). Slide the Height Adjustment Bar into the hole at the top of the Vertical Bar. The holes in the Height Adjustment Bar should be at the back.

4. Adjust the height to where you want it, aligning one of the holes in the Height Adjustment Bar with the nut hole at the back of the Vertical Bar.

5. Screw the Tightening Knob through the nut at the back of the Vertical Bar and the hole at the back of the Height Adjustment Bar. Screw it in until tight. Make sure that the Height Adjustment bar will not slide down any further.

6. Slide the bottom of your light box into the Bracket Piece. The front of the unit (the face with the diffuser) should be angled downward toward the front of the stand. Your light box is now ready for use on its Floor Stand.

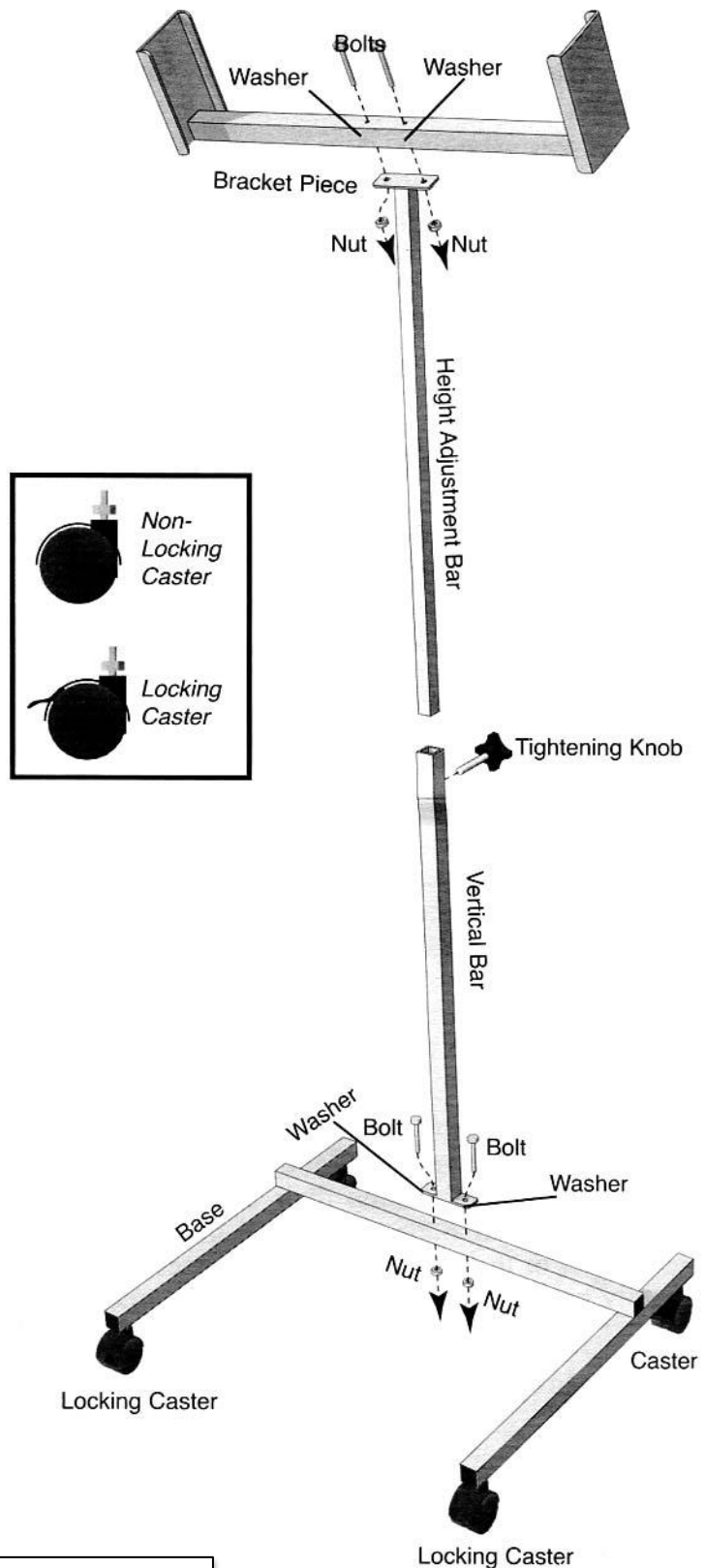

**NOTE:** Never attempt to disassemble, assemble, or adjust the stand while your SunSquare+™ is in the Bracket Piece. Failure to remove the light box from the stand before making adjustments may put you at risk of injury.

# SunBox® SunSquare+™ Bulb Replacement

## step 3: remove seven screws

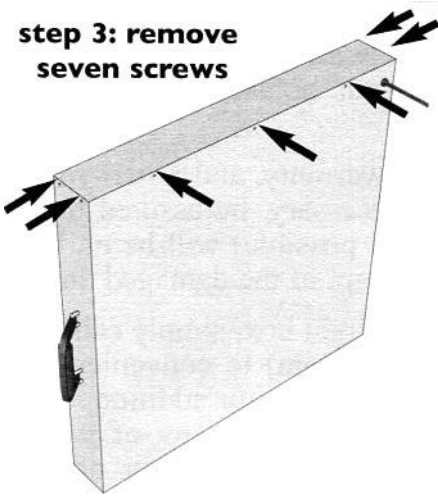

1. Make sure your SunSquare+™ is not plugged into a wall outlet.
2. Remove the light box from its stand.
3. Stand the SunSquare+™ on its end. Using a #1 Phillips head screwdriver, remove the seven screws (positions indicated in the illustration to the left) that hold the end panel in place. If a # 1 Phillips head screwdriver doesn't seem to fit, you're trying to remove the set of screws at the wrong end of the box. In this case, flip the unit over then unscrew.
4. Remove the end piece, and slide the diffuser out.
5. Lay your SunSquare+™ unit on its back.
6. Remove the screw and washer from the bulb clamp of the bulb you are replacing. It is best to replace one bulb at a time.
7. Press down on the red socket locks at the other end of the bulb. The socket and diffuser locks will rotate, freeing the pins at the end of the bulb.

8. Lift the old bulb straight up while pressing down on the socket locks. If the old bulb is broken, be very careful not to cut yourself. Also, be sure to remove any broken glass.
9. Place the new bulb clamp (provided with the new bulb) on the replacement bulb.
10. Put the new bulb in place. The red socket locks should still be in the unlocked position. Align the four pins at the end of the bulb with the four slots at the top of the sockets. Push the bulb down to lock the pins in place. The downward pressure will cause the socket locks to swing up into the locked position.
11. Screw the bulb clamp into place using the screw and washer you removed in step 6 above.
12. Slide the diffuser back into place with the rough textured surface at the outside of tile unit. Then reinsert the end piece and screw it into place using the seven screws you removed in step 3 above.
13. Plug the light box in and turn it on to test your new bulb.

## step 4: remove end piece and diffuser



**NOTE: Your light box has a built-in safety mechanism designed to reduce your risk of electrical shock. Step 12 must be performed before the bulbs will light.**

## step 7: press down

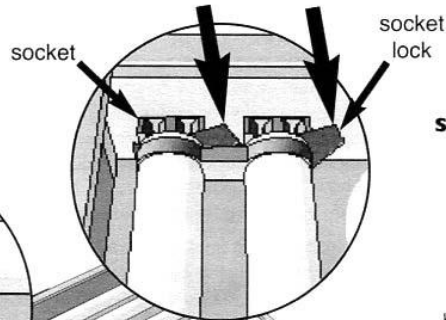

## step 6: remove screw & washer

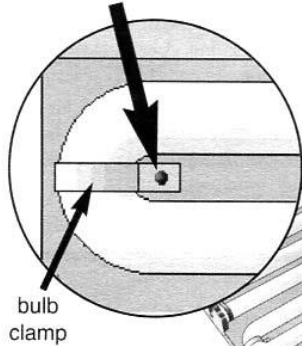

## step 8: remove old bulb

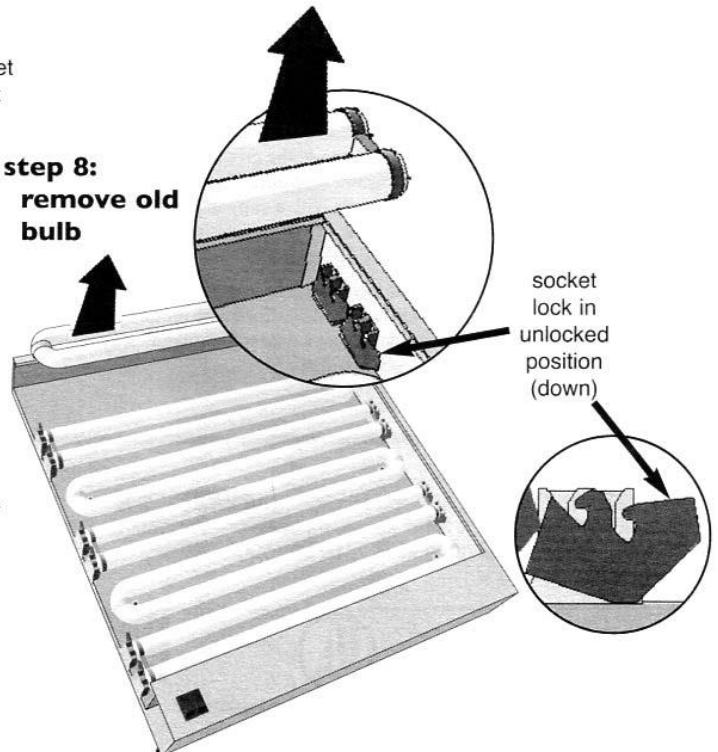

## Our Commitment to You



The SunBox® Company will provide you with valuable customer service, which continues well beyond your actual SunBox® purchase.

Your SunSquare+™ comes with a lifetime warranty, with a two (2) year guarantee on the bulbs, excluding breakage. Should a covered repair be necessary during this warranty period, be assured that your unit (or a replacement, if repair is not possible) will be shipped back to you within 48 hours of SunBox® getting the damaged unit.

---

### REMINDER TO REPLACE YOUR BULBS

Because bulbs lose intensity with use and continued use of old fluorescent bulbs can damage the ballast, we recommend that you change your bulb frequently. Do not wait until your bulbs burn out to replace them! \*To maintain the warranty, you must replace the bulbs every three (3) years. Failure to do so will void the warranty regardless of use. You can place an order online 24 hours a day from our website- [www.sunbox.com](http://www.sunbox.com)

---

If, for any reason, you encounter problems with your SunSquare+™, contact us at 800-548-3968 or 301-869-5980.

---

**Limited Warranty/Guarantee:** The SunBox® Company, Inc. (us, we, our) warrants to the original purchaser (you, your) that the SunSquare+® (light unit, unit) is to be free from defects in material and workmanship **under \*normal use and service for the life of the product**. Our entire liability and your exclusive remedy as to the unit(s) shall be repair or replacement of the unit, at our option, when returned to us with a copy of the receipt. You shall be responsible for the cost of returning the unit to us with a copy of the receipt plus \$35 return shipping via UPS. If failure of the unit has resulted from accident, abuse, or misapplication, we shall have no responsibility to replace or repair the unit. Any replacement unit will be warranted for the remainder of the original warranty period. Fluorescent bulbs are guaranteed for two years against failure. **Fluorescent bulbs must be replaced every 3 years for this warranty to remain valid.** (Shipping cost subject to change)

The above are the only warranties of any kind, either express or implied, including but not limited to the implied warranties of merchantability and fitness for a particular purpose, that are made by The SunBox® Company on this product. No oral or written information or advice given by The SunBox® Company, its dealers, distributors, agents, or employees shall create a warranty or in any way increase the scope of this warranty. This warranty gives you specific legal rights. You may have other rights, which vary from state to state.

Specifications: 110V AC 60Hz 186 watts 2 A

Dimensions: 23" W x 24" H x 3.25" D (not including stand) Weight: 19.5 lbs plus stand

Also available in 220 V